

Simulation-based Inference of Beamline Characteristics at BESSY



Peter Steinbach¹ and Gregor Hartmann²

¹Helmholtz-Zentrum Dresden-Rossendorf, Dresden, Germany

²Helmholtz-Zentrum Berlin für Materialien und Energie (HZB), Berlin, Germany

Motivation

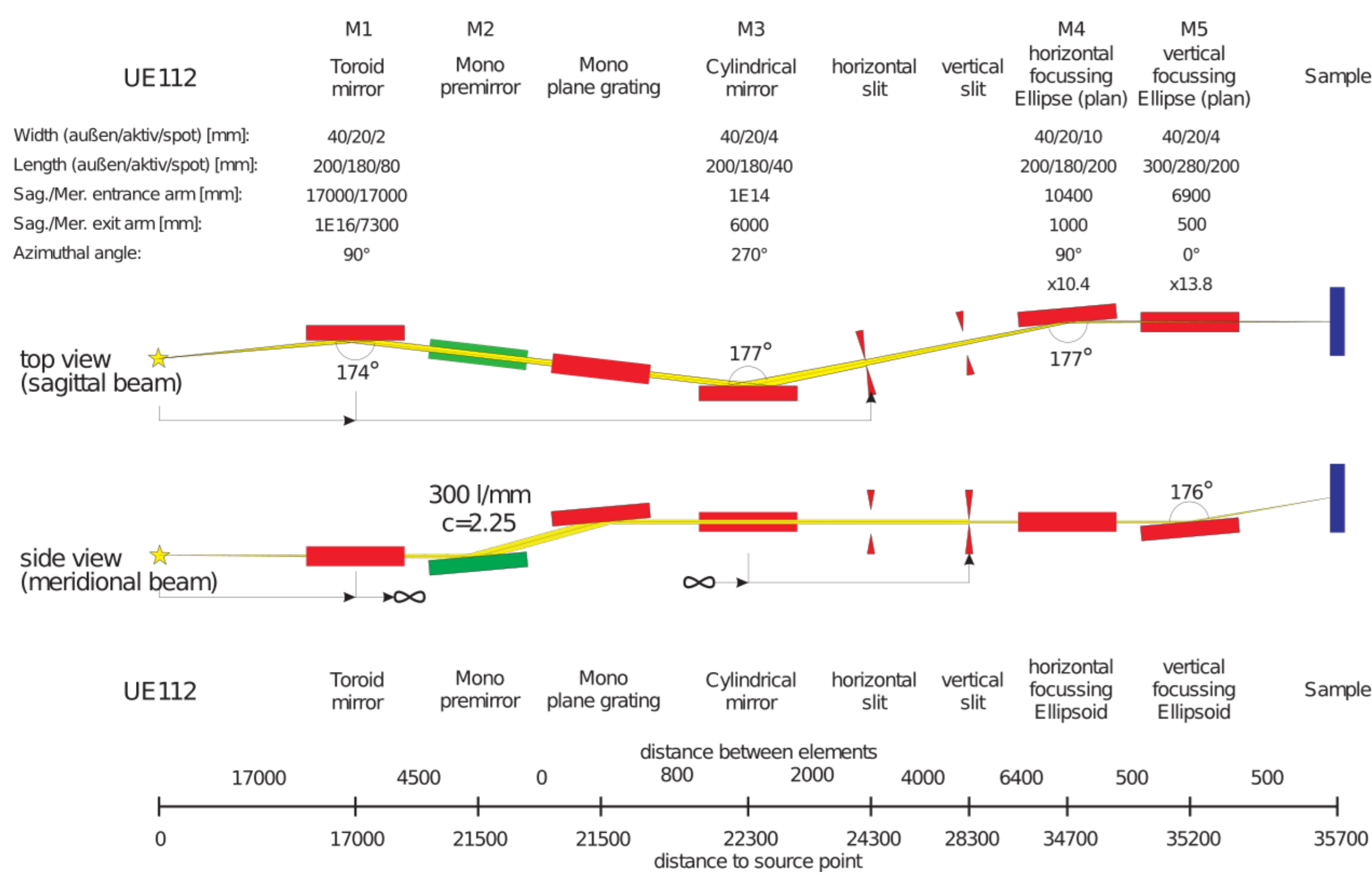

Simulation



Experiment?

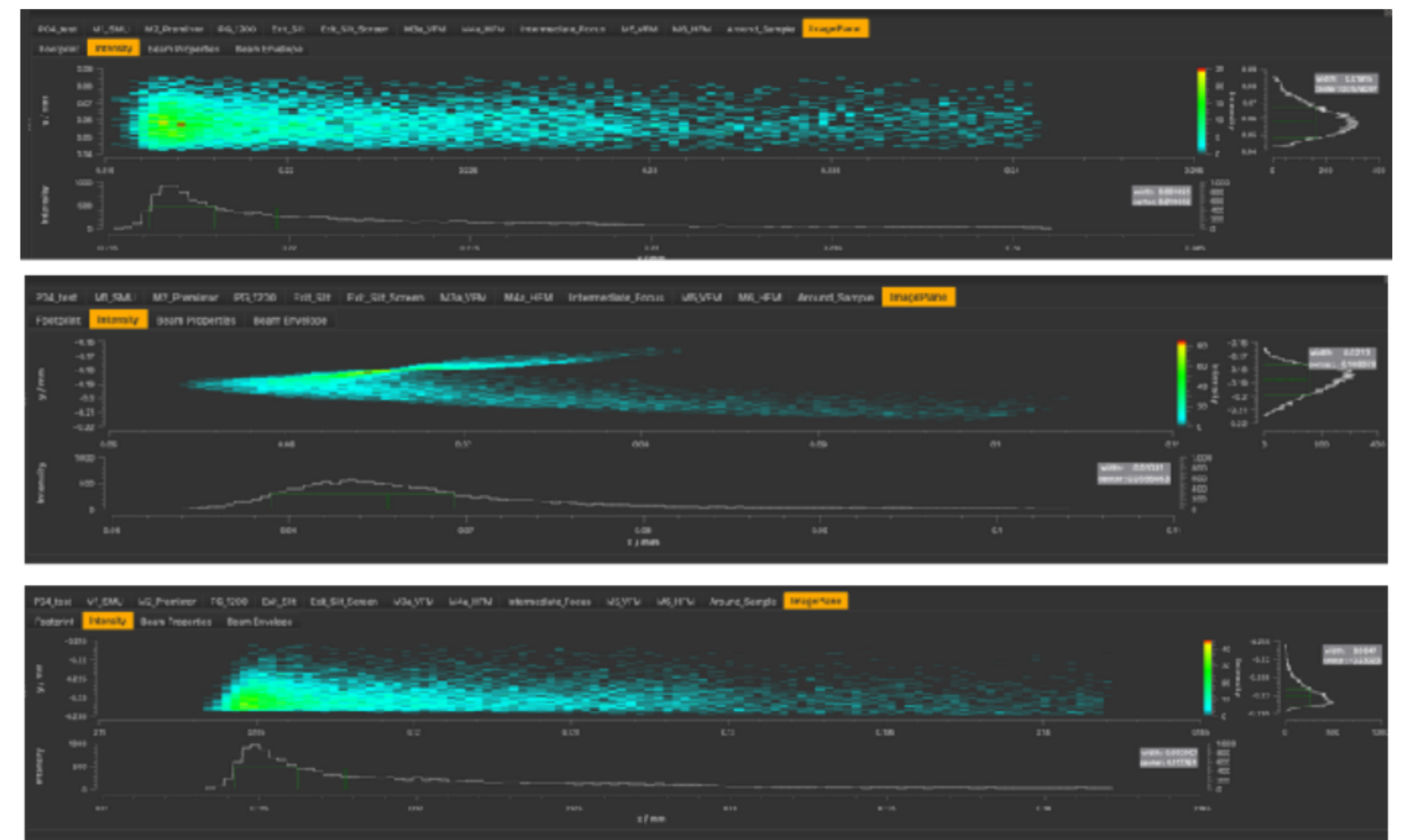

Beam Profile \vec{x} at Sample Position

Beamline Parameters $\vec{\vartheta}$ towards Sample

Bayesian Inference on Inverse Problems

$$p(\vec{\vartheta}|\vec{x}) = \frac{p(\vec{x}|\vec{\vartheta}) \cdot p(\vec{\vartheta})}{\int p(\vec{x}|\vec{\vartheta}') \cdot p(\vec{\vartheta}') d\vec{\vartheta}'}$$

- ▶ likelihood $p(\vec{x}|\vec{\vartheta})$ described by simulation (forward process)
- ▶ prior $p(\vec{\vartheta})$ known from simulation configuration within meaningful physical limits
- ▶ goal: obtain posterior $\hat{p}(\vec{\vartheta}|\vec{x})$ from experimental data (backward process)

Normalizing Flows!

- ▶ ideal to **map** probability density function $p(\vec{x}_i|\vec{\vartheta}_i)$ **onto** another probability density function $\hat{p}(\vec{\vartheta}_i|\vec{x}_i)$
- ▶ using affine coupling blocks inspired invertible neural networks (INN,[1])

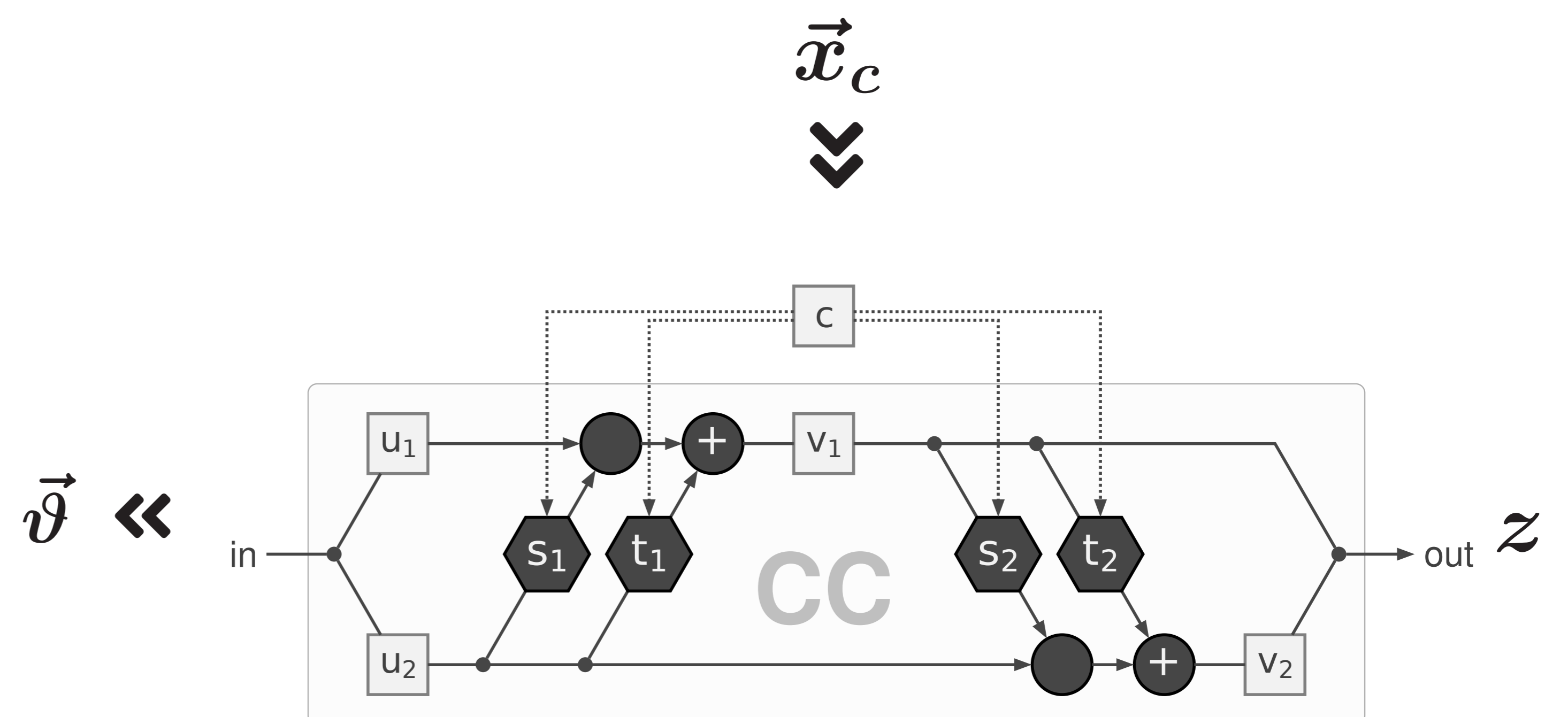

Pre-Alpha-Stage Preliminary Results

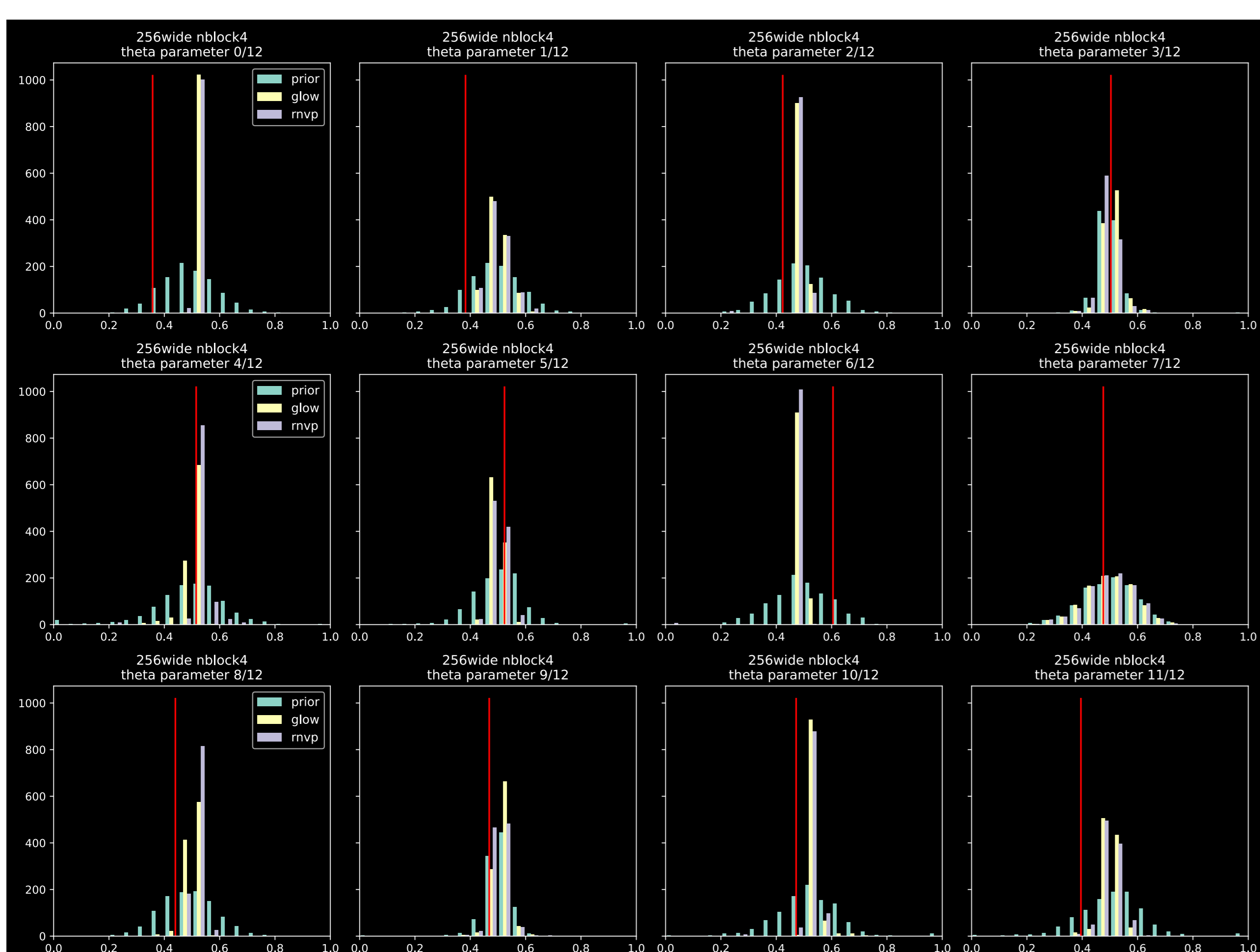

Maximum a posteriori (MAP) estimate for single validation sample using conditional INN (based on [3])

- ▶ affine coupling blocks based conditional Invertible Neural Network shows promising results
- ▶ currently validating architecture, data sets and training
- ▶ comparison to SNPE-C [2] (Sequential Neural Posterior Estimator) ongoing

References:

[1] L. Ardizzone, C. Lüth, J. Kruse, C. Rother, and U. Köthe. Guided image generation with conditional invertible neural networks.
 [2] D. S. Greenberg, M. Nonnenmacher, and J. H. Macke. Automatic posterior transformation for likelihood-free inference.
 [3] S. T. Radev, U. K. Mertens, A. Voss, L. Ardizzone, and U. Köthe. BayesFlow: Learning complex stochastic models with invertible neural networks.